

THIS DRAWING IS UNPUBLISHED. RELEASED FOR PUBLICATION, 19  
 © COPYRIGHT 19 BY AMP INCORPORATED. ALL INTERNATIONAL RIGHTS RESERVED.

LOC	DIST	P	F	REVISIONS			
ZONE	LTR	DESCRIPTION	DATE	APPD			
AF	50			B	REL PER 063A-0580-01	150CT01	JR/PD

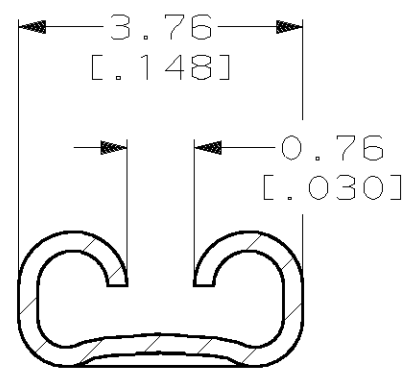
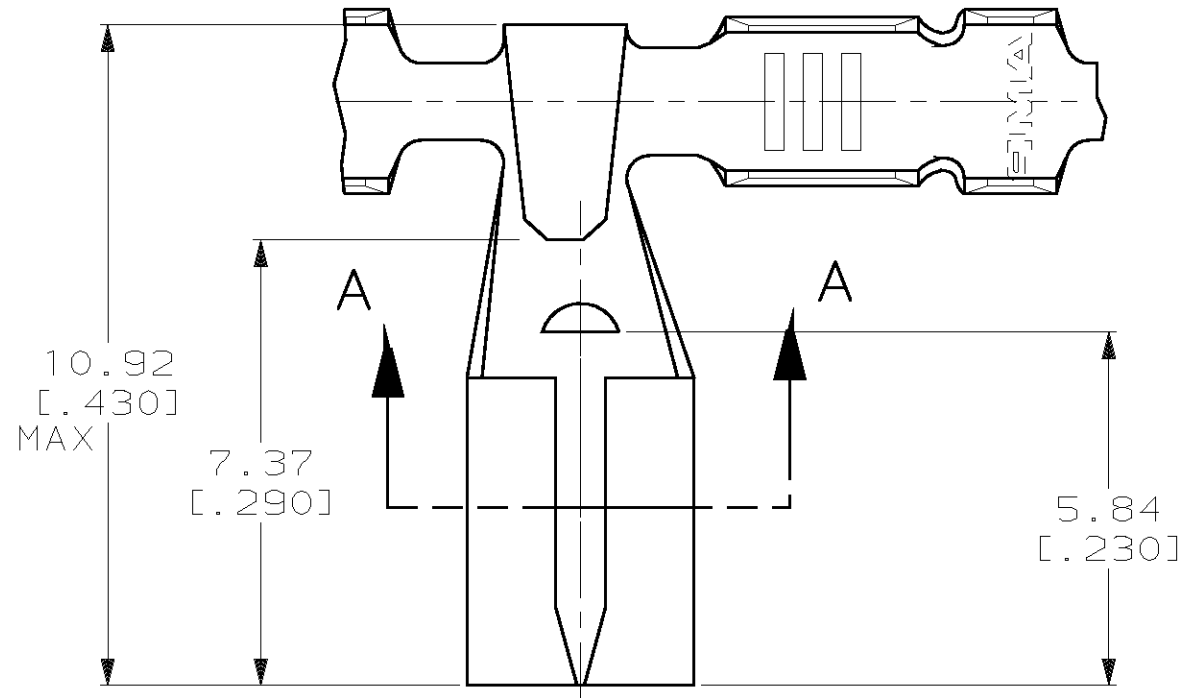

SECTION A-A  
SCALE 10:1

- CONTINUOUS STRIP ON REELS
- WIRE SIZE IS [#22-#18] AWG.
- INSULATION RANGE IS 1.52-2.54 [.060-.100] DIA.
- MATING TAB THK TO BE 0.81±0.025 [.032±.001].

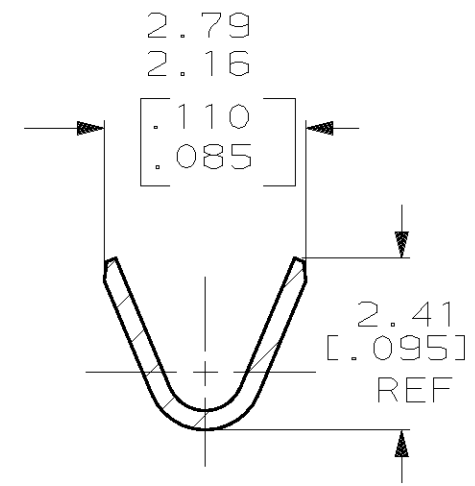

SECTION B-B  
SCALE 10:1

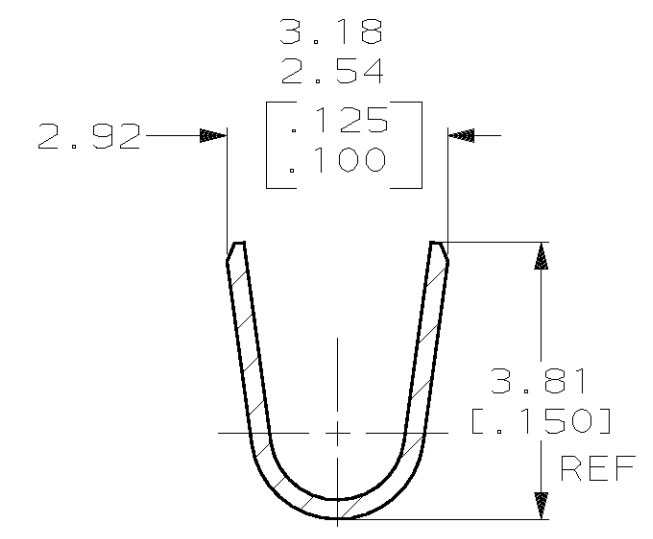

SECTION C-C  
SCALE 10:1

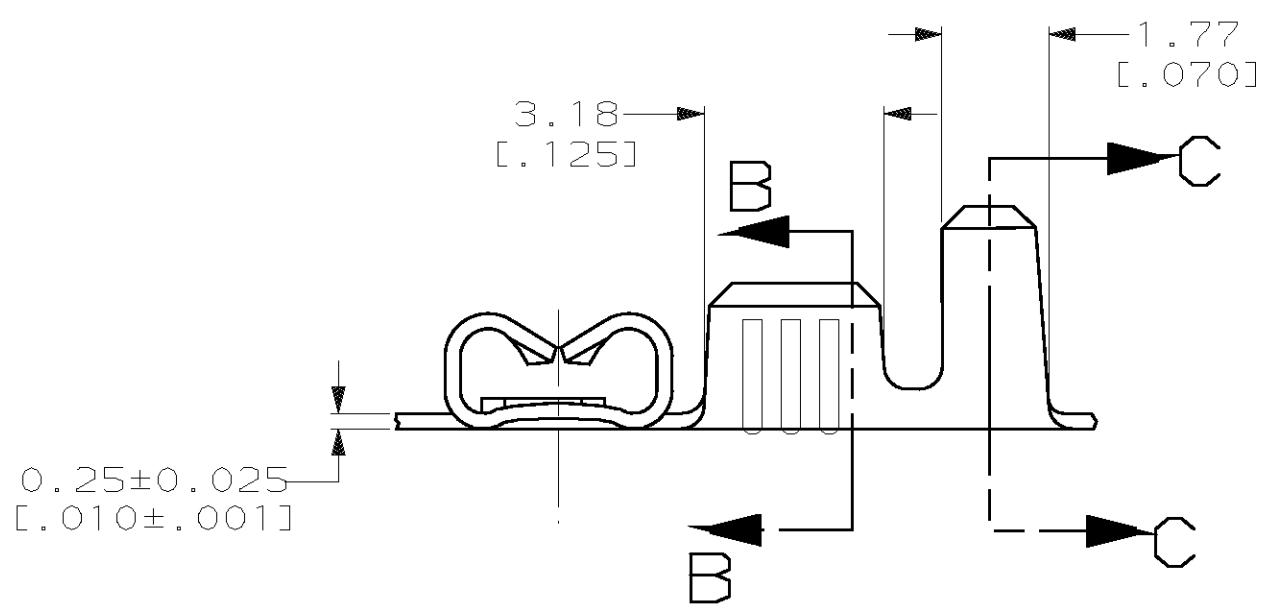

1217171-1  
PART NO

DO NOT SCALE PRINT. UNLESS SPECIFIED DIMENSIONS ARE IN MM [INCHES] TOLERANCES ON: 2 PLC DEC ± - 3 PLC DEC ± 0.25 [.010] ANGLES ± - MATERIAL H04 BRASS FINISH TIN PLATE	DR 07JUN99 JR RUTH	<b>AMP</b> AMP Incorporated Harrisburg, PA 17105-3608 NAME RECEPTACLE, FASTON, FLAG, 2.79 [.110] SERIES SIZE B CAGE CODE 00779 DRAWING NO 1217171 SCALE 8:1 SHEET 1 OF 1
	CHK 07JUN99 MS FEHER	
	APPD 07JUN99 S HEADER	
	APPD 07JUN99 D ROTELL	
	PRODUCT SPEC -	
	APPLICATION SPEC -	
	WEIGHT -	